

AVENTOS HK top

www.blum.com

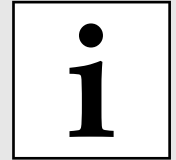

AVENTOS HK top



Standardanwendungen | Standard applications | Applications standard | Applicazioni standard | Aplicaciones estándar |
Rozwiązania standardowe | Стандартные конструкции

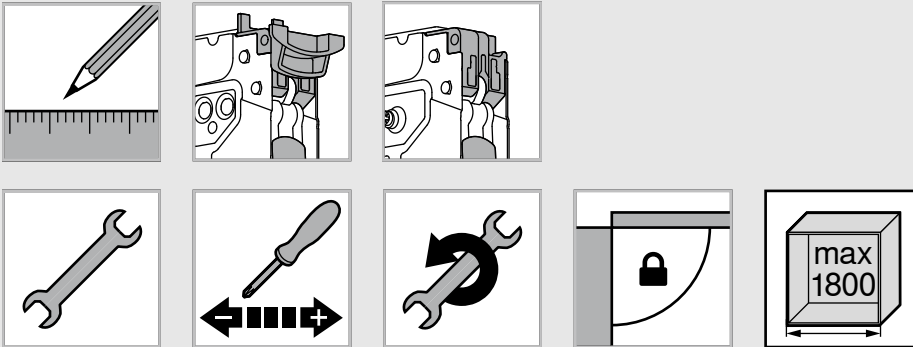

Sonderanwendungen | Special applications | Applications spéciales | Applicazioni speciali |
Aplicaciones especiales | Rozwiązania specjalne | Специальные конструкции



Planung | Planning | Planification |
Progettazione | Planificación | Planowanie |
Проектирование

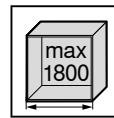

Korpusbreite | Cabinet width | Largeur corps de meuble |
Larghezza corpo mobile | Ancho de cuerpo de mueble |
Szerokość korpusu

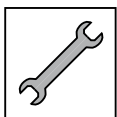

Montage | Assembly | Montage | Montaggio |
Montaje | Montaž | Монтаж

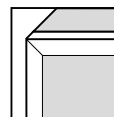

Schmaler Alurahmen | Narrow alu frame | Cadre alu
étroit | Telai in alluminio stretti | Marcos de alumi-
nio estrechos | Wąskie ramki aluminiowe | Узкая
алюминиевая рамка



Einstellung | Adjustment | Réglage | Regolazione |
Ajuste | Regulacja | Регулировка

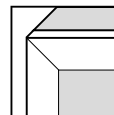

Breiter Alurahmen | Wide alu frame | Cadre alu large |
Telai in alluminio larghi | Marcos de aluminio anchos |
Szerokie ramki aluminiowe | Широкая алюминиевая
рамка

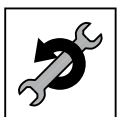

Demontage | Removal | Démontage | Smontaggio |
Desmontaje | Demontaž | Демонтаж

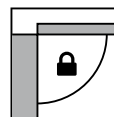

Öffnungswinkelbegrenzer | Opening angle stop |
Limiteur d'angle d'ouverture | Limitatore angolo di
apertura | Limitador de apertura | Ogranicznik kąta
otwarcia | Ограничитель угла открывания

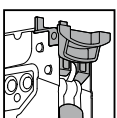

Kraftspeicher für Spanplattenschrauben

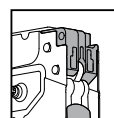

Kraftspeicher mit integrierten Systemschrauben



Klickbar | Clickable | Cliquable |
Cliccabile | Se puede hacer clic |
Klikalny | Кликабельно



Nicht Klickbar | Not clickable |
Pas cliquable | Non cliccabile |
No se puede hacer clic |
Nie klikalny | Некликабельно



Zurück | Back | Retour | Indietro |
Hacia atrás | Wstecz | Назад

AVENTOS HK top

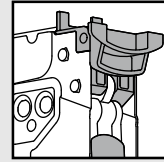

i

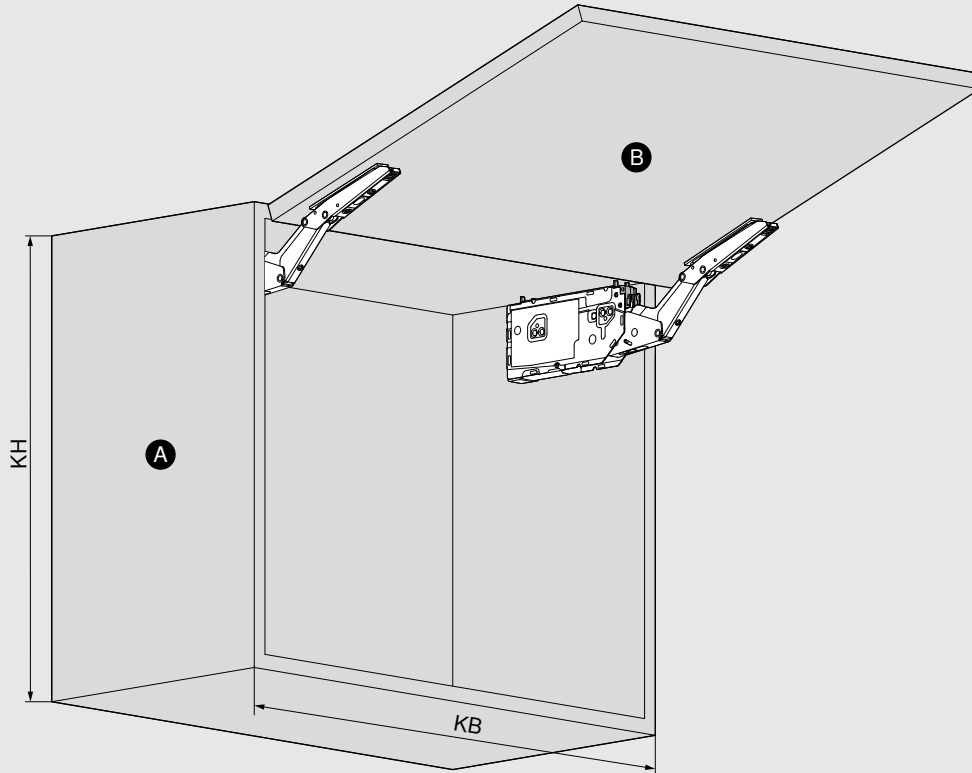

1

2 x

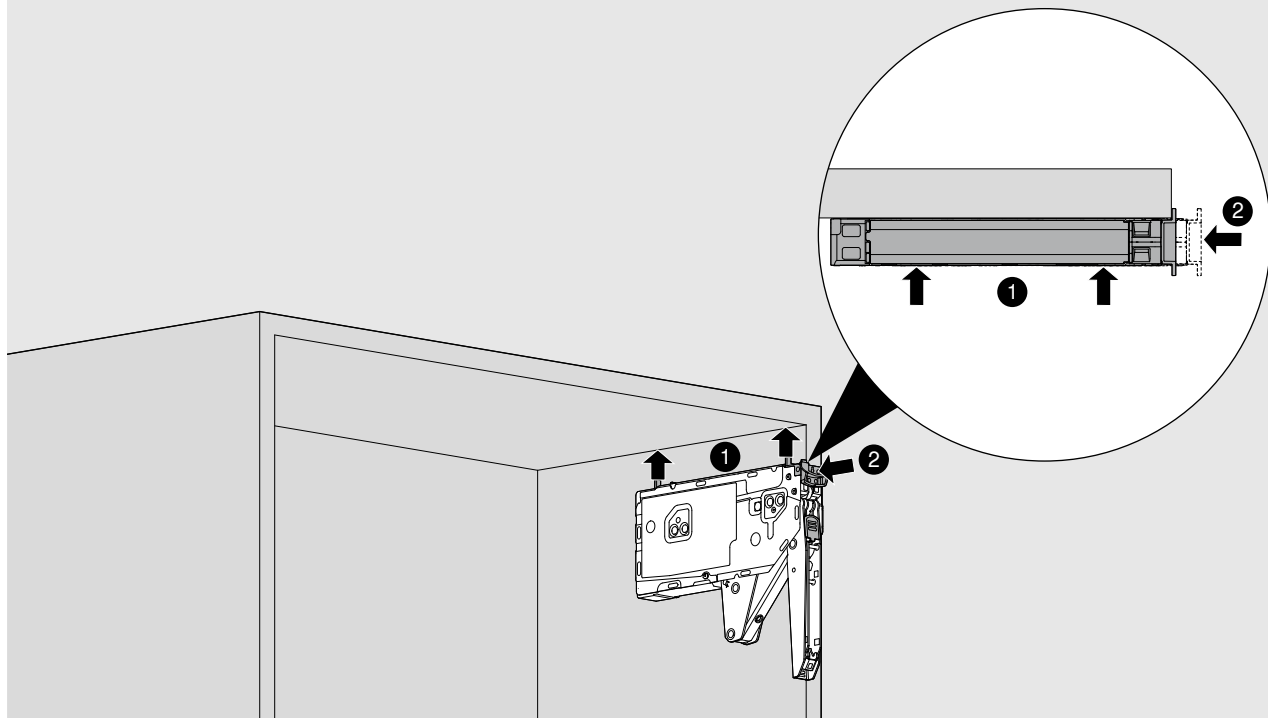
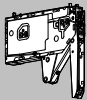

AVENTOS HK top

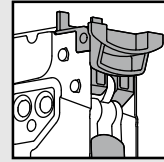

2

4 x  (4 x 35)

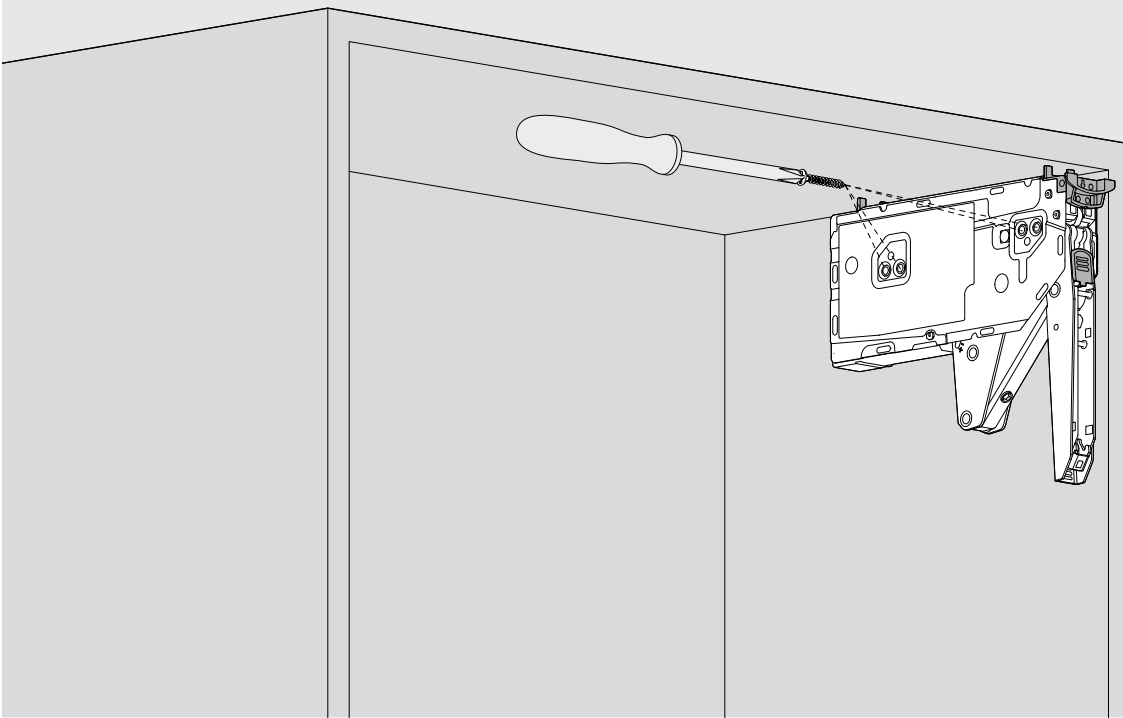

3

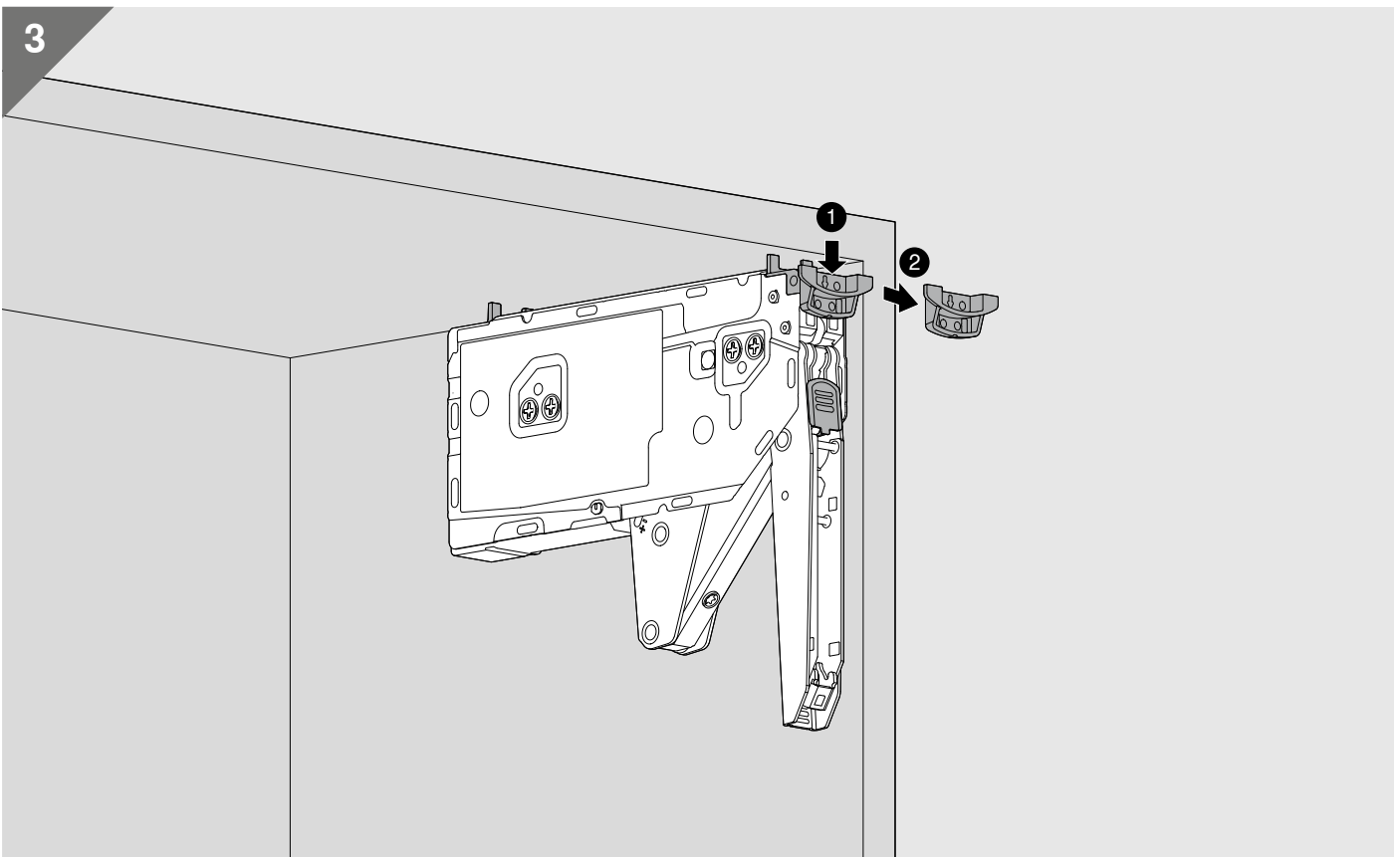

AVENTOS HK top

 **blum**

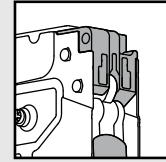

1

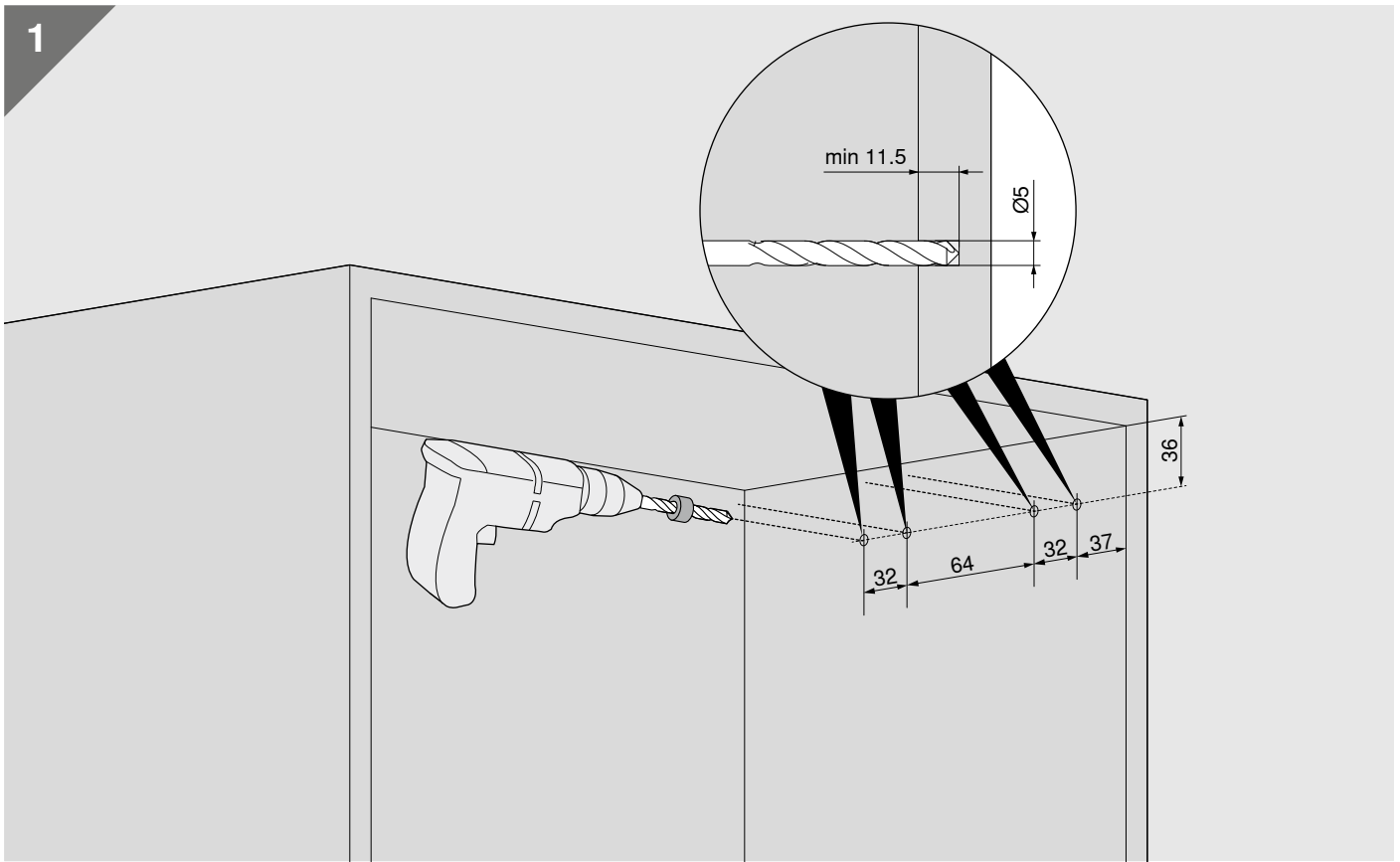

2

2 x

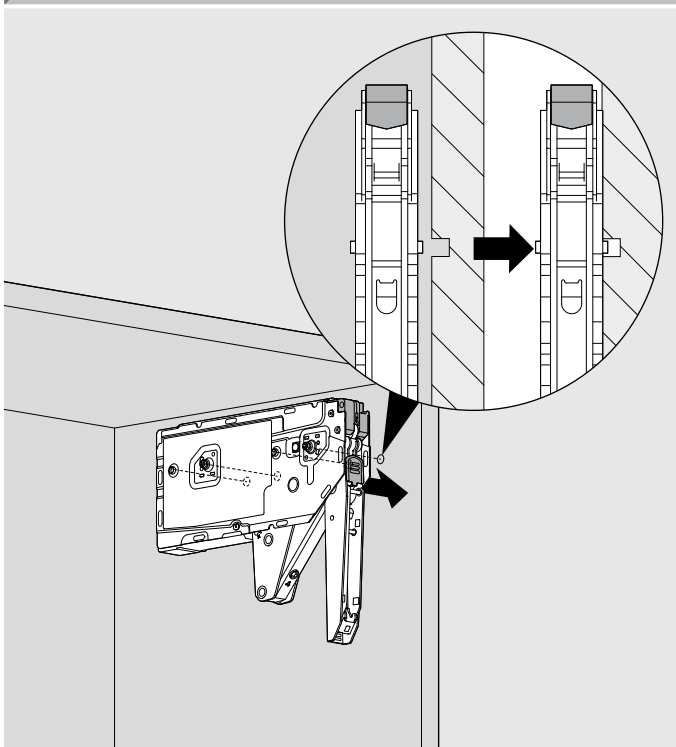
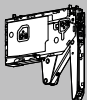

3

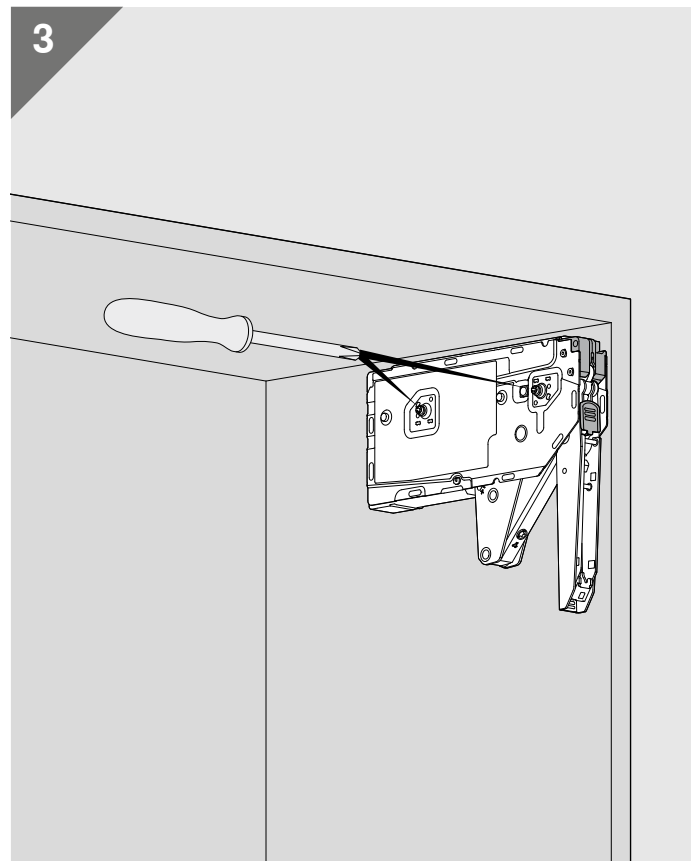



i

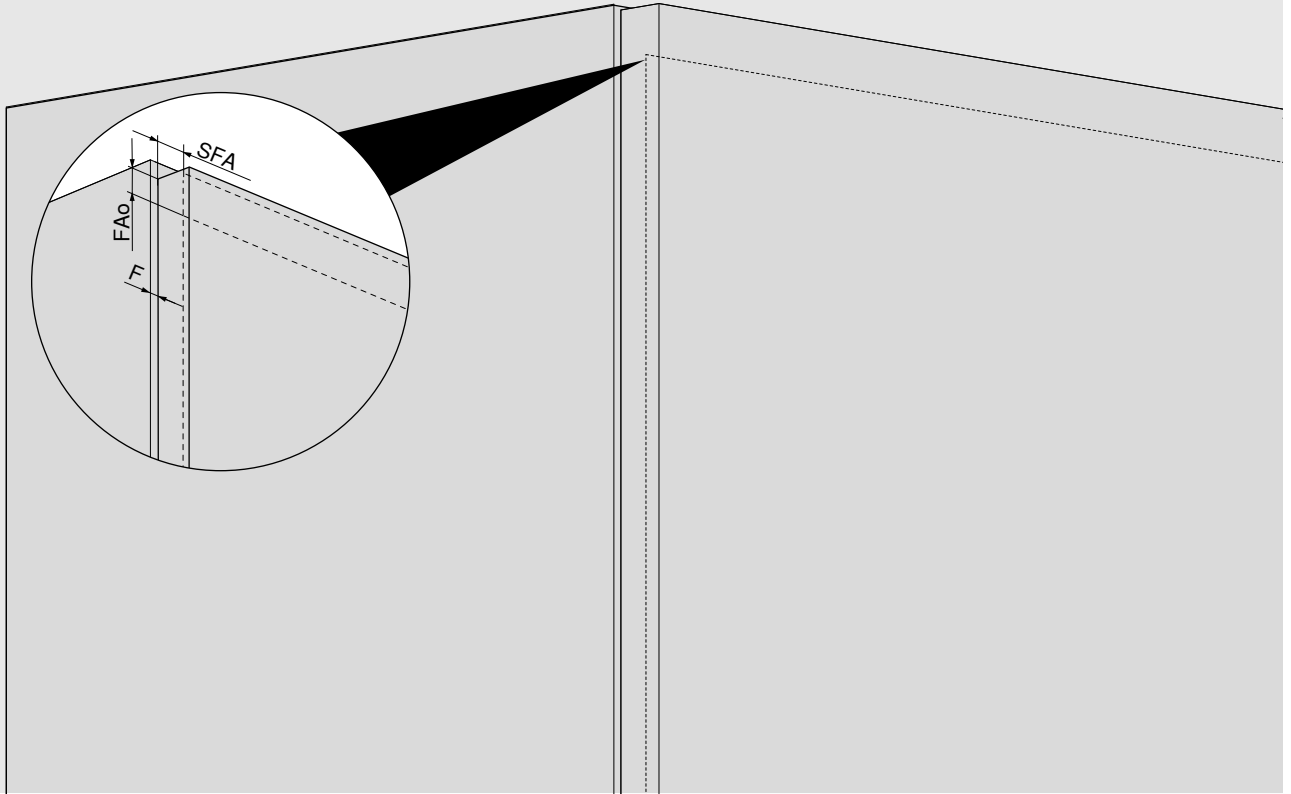

i

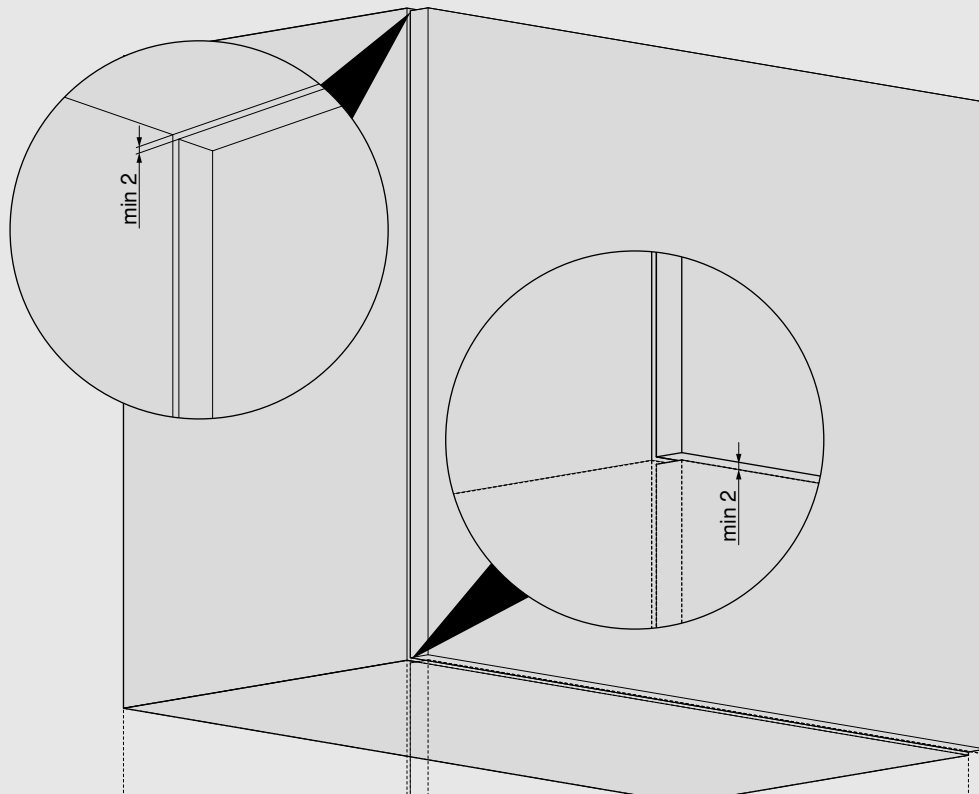

AVENTOS HK top



i

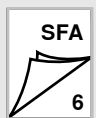
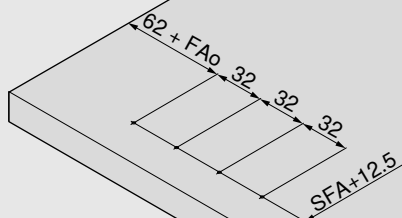

1

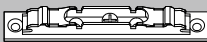
8 x  (3.5 x 15) 2 x 

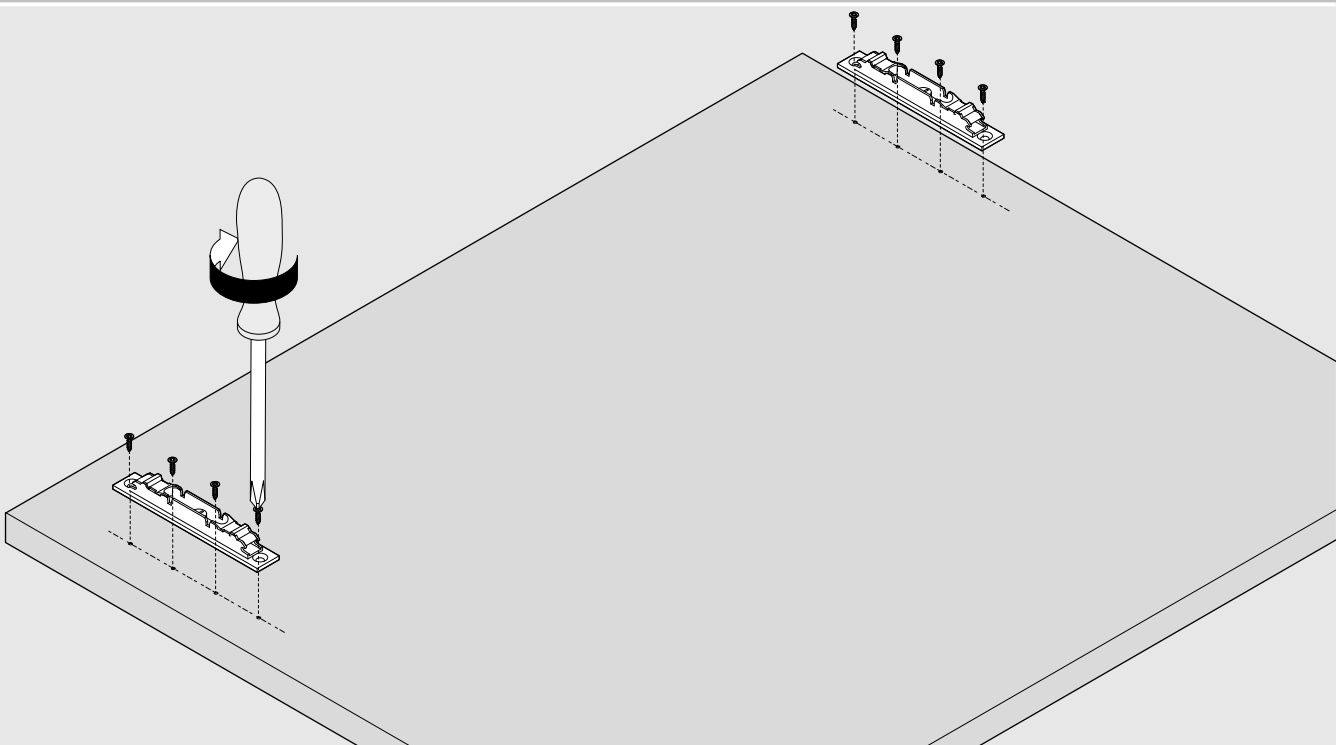

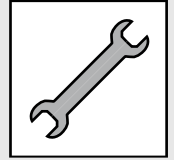

**WARNING | WARNING | AVERTISSEMENT | AVVERTENZA |
ADVERTENCIA | OSTRZEŻENIE | ВНИМАНИЕ | 警告**

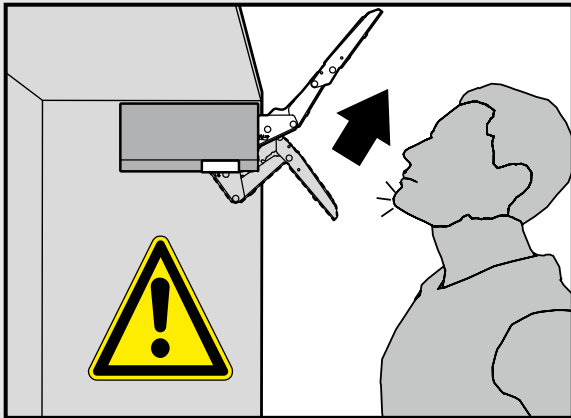

- Hebel nicht spannen.
Do not close the lever arm!
Ne pas armer le bras.
Non tendere la leva verso il basso.
No empulgar el brazo.
Nie opuszczać podnośnika.
Не опускайте рычаг.

- Verletzungsgefahr durch hochspringenden Hebel!
Lever could spring up and cause injury!
Risque de blessure en cas de relevage brusque du levier!
Pericolo di lesioni a causa del possibile scatto della leva verso l'alto!
Peligro de lesión por elevación de la palanca!
Niebezpieczeństwo zranienia przez gwałtownie unoszący się podnośnik!
Существует опасность получения травмы при выскакивании рычага!

1

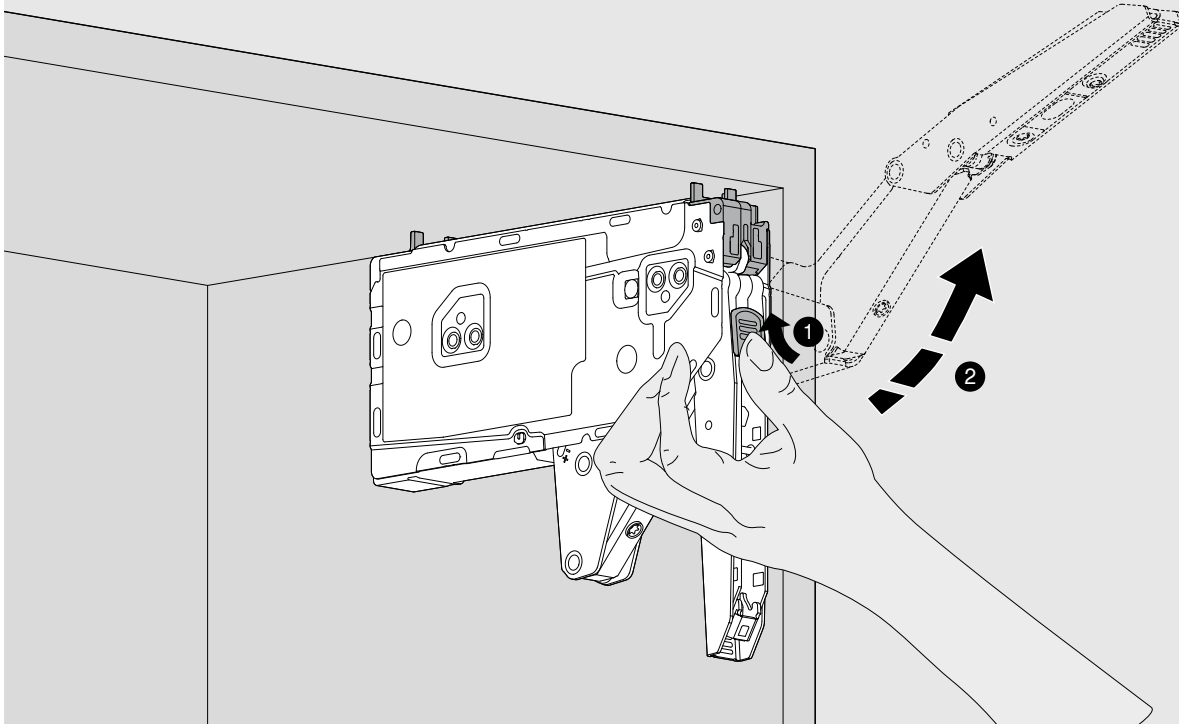

AVENTOS HK top

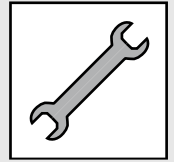

2

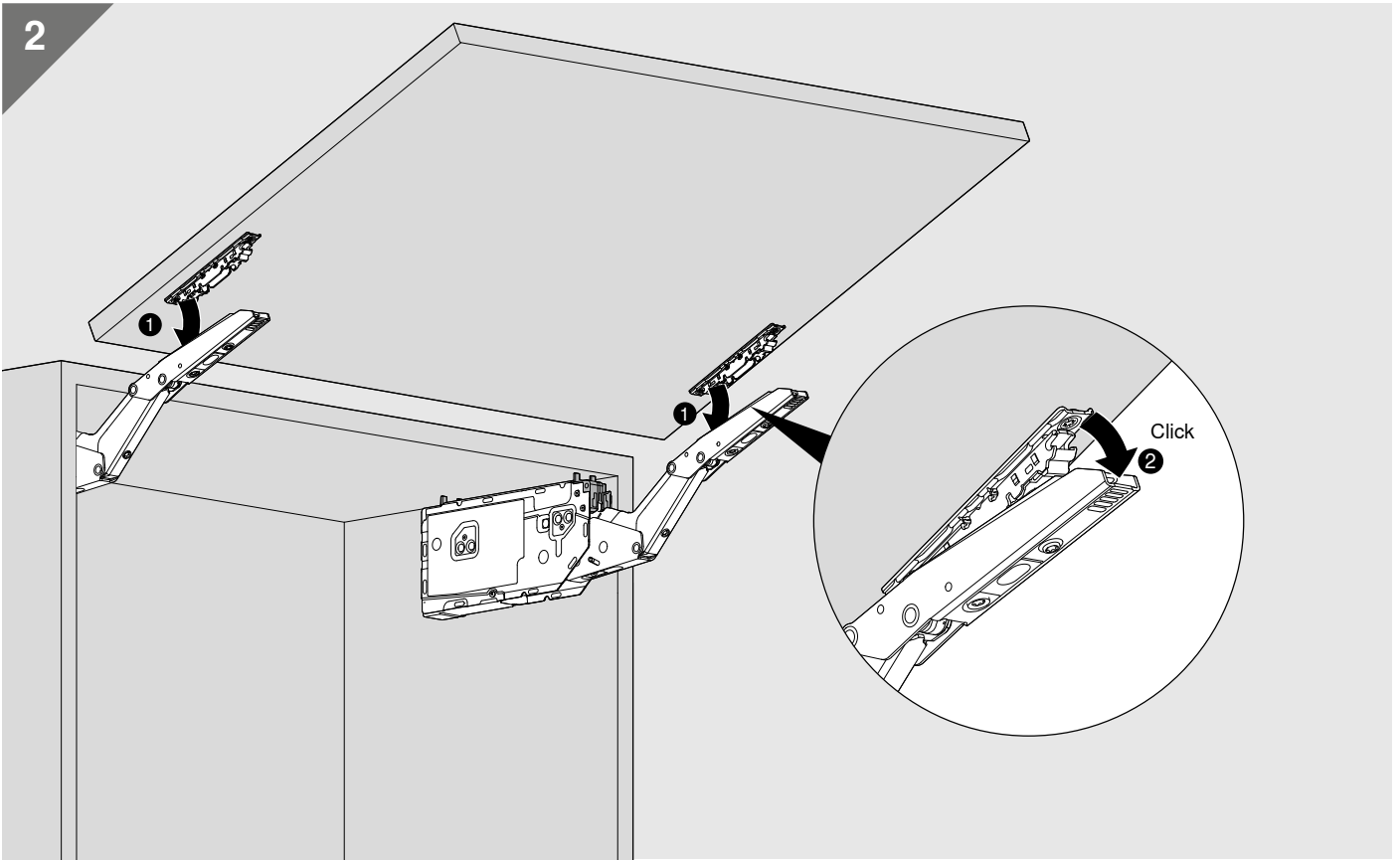

3

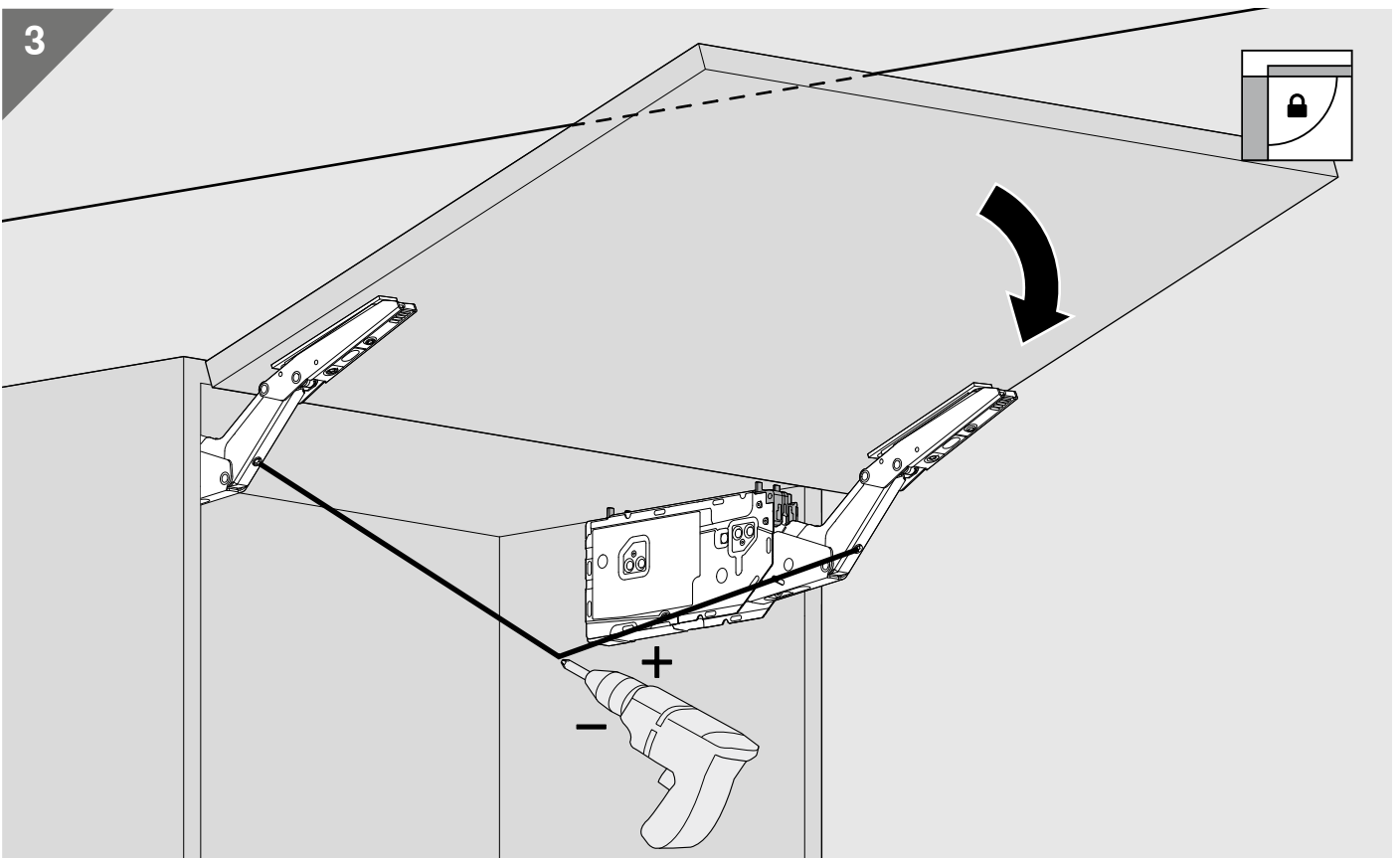

AVENTOS HK top

 **blum**

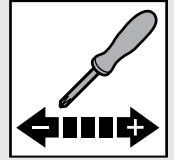

1

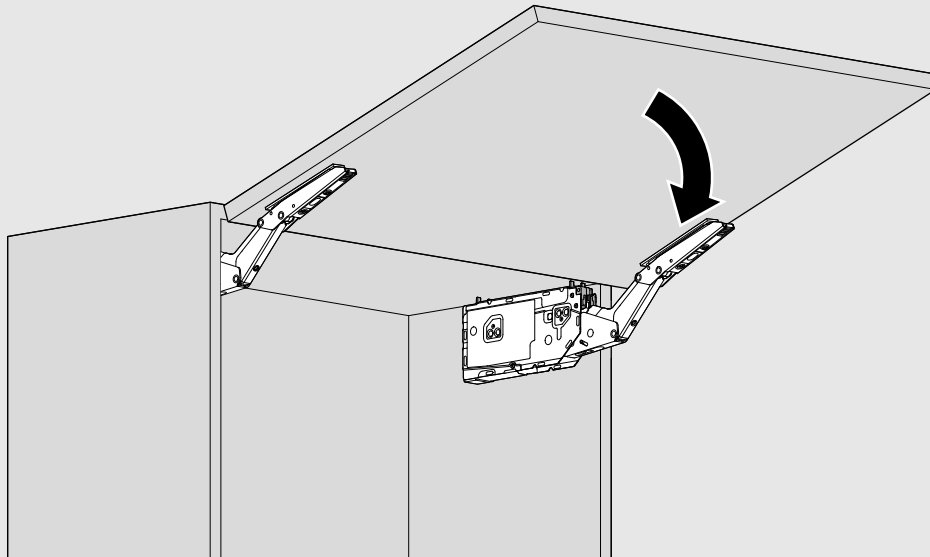

2

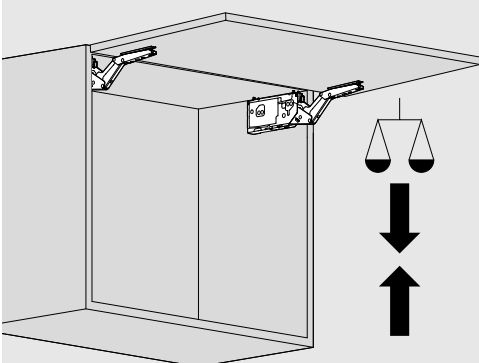
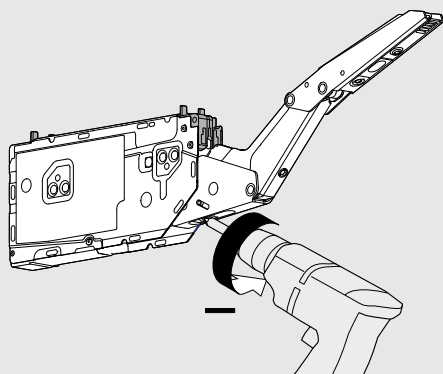
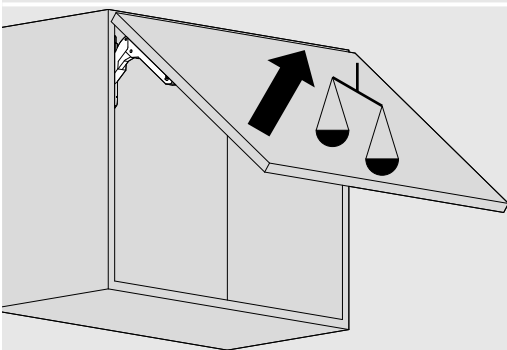
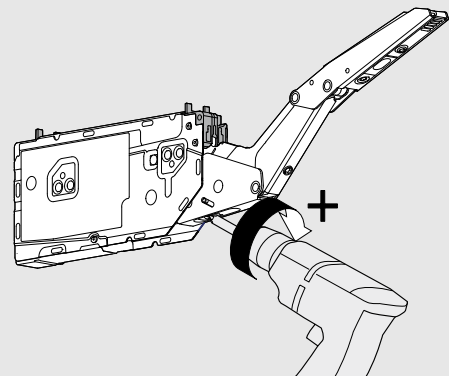
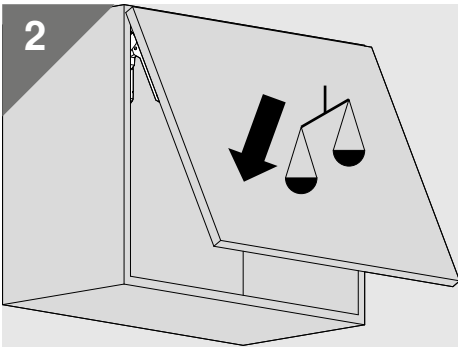

AVENTOS HK top

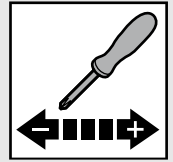

3

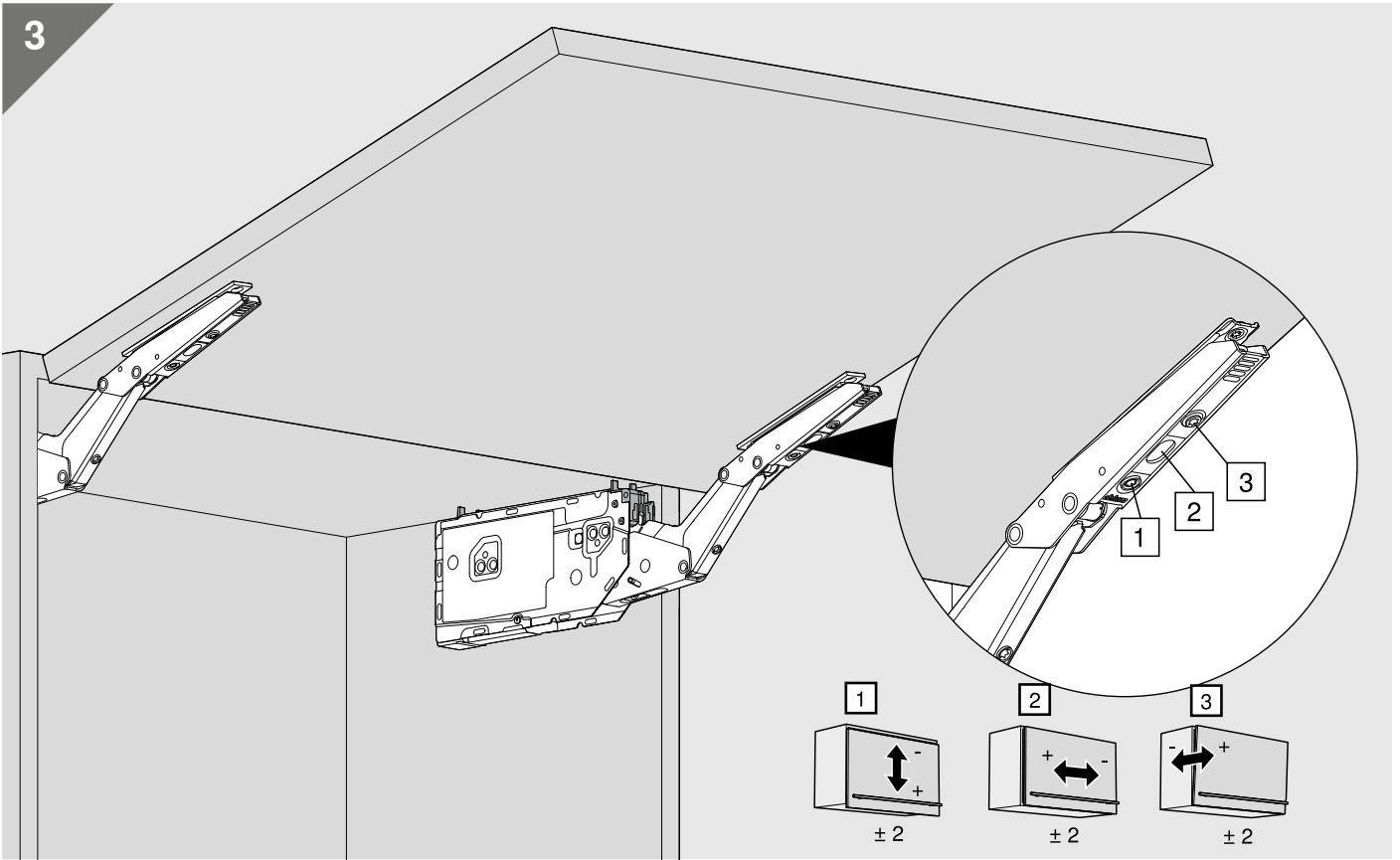

4

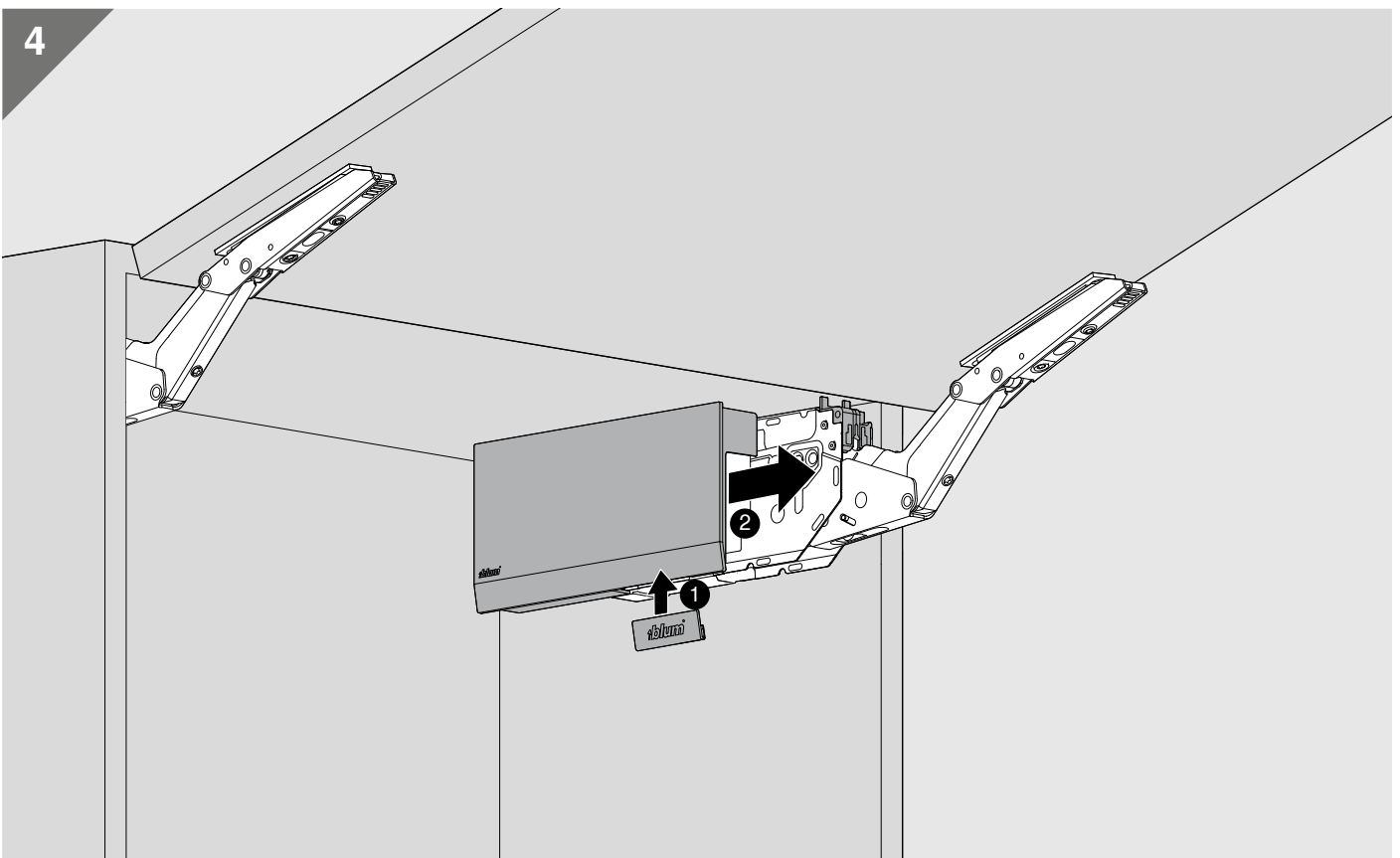

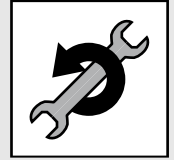

**WARNING | WARNING | AVERTISSEMENT | AVVERTENZA |
ADVERTENCIA | OSTRZEŻENIE | ВНИМАНИЕ | 警告**

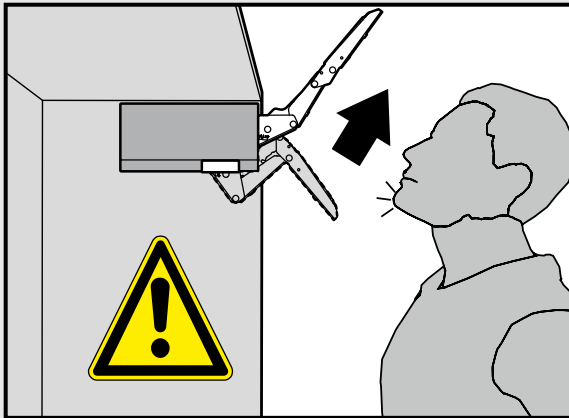

- Hebel nicht spannen.
Do not close the lever arm!
Ne pas armer le bras.
Non tendere la leva verso il basso.
No empulgar el brazo.
Nie opuszczać podnośnika.
Не опускайте рычаг.

- Verletzungsgefahr durch hochspringenden Hebel!
Lever could spring up and cause injury!
Risque de blessure en cas de relevage brusque du levier!
Pericolo di lesioni a causa del possibile scatto della leva verso l'alto!
Peligro de lesión por elevación de la palanca!
Niebezpieczeństwo zranienia przez gwałtownie unoszący się podnośnik!
Существует опасность получения травмы при выскакивании рычага!

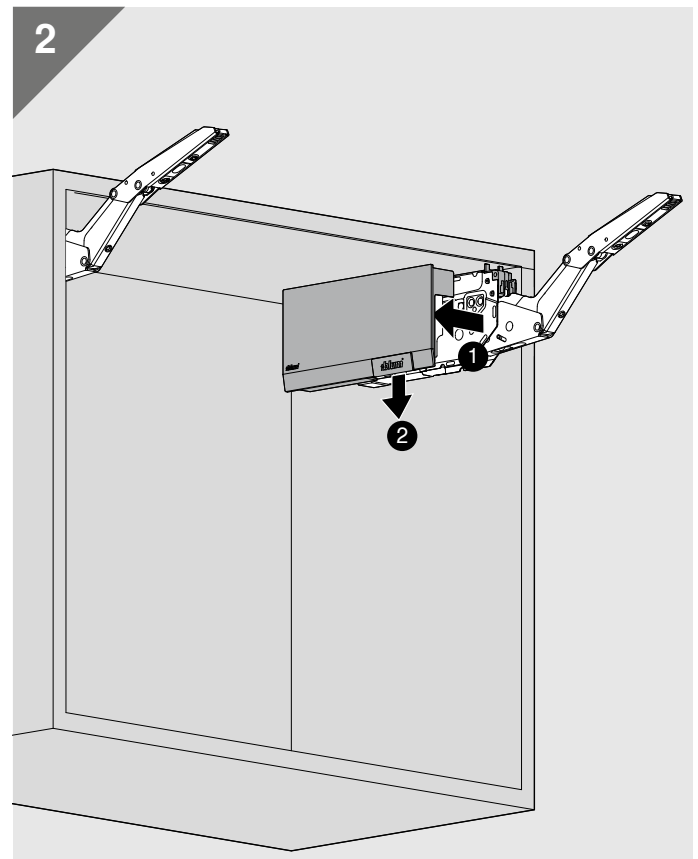
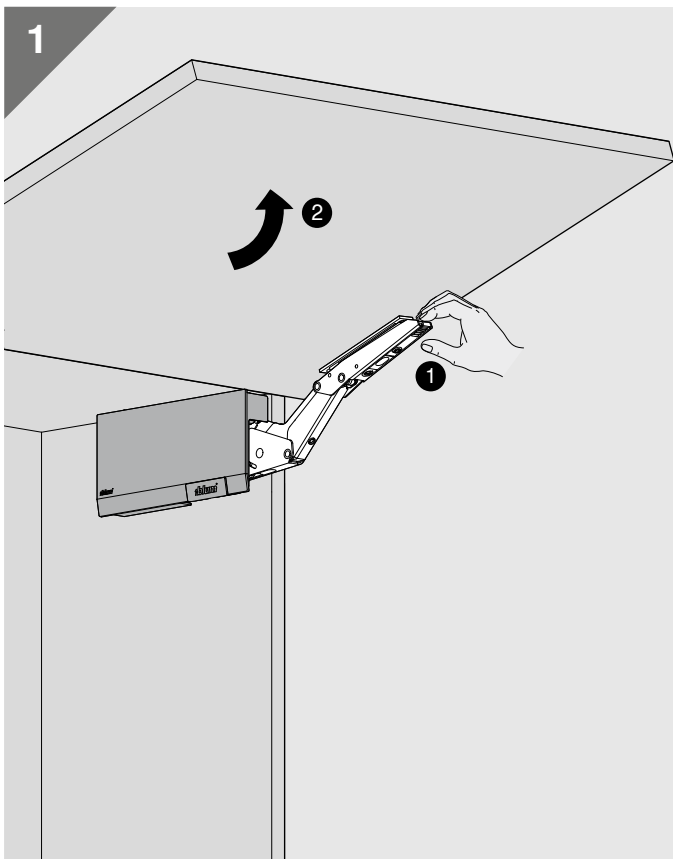

AVENTOS HK top





WARNING | WARNING | AVERTISSEMENT |
AVVERTENZA | ADVERTENCIA | OSTRZEŻENIE |
ВНИМАНИЕ | 警告

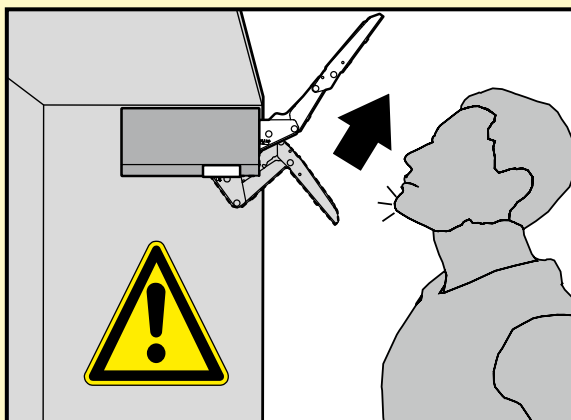

AR	لا تغلق ذراع الرافعة!	مناك خطورة عندما يتحرك ذراع الرافعة ربما يحدث إصابة
BG	Да не се съгва лоста на повдигащия пакет!	Опасност от нараняване от повдигащото рамо!
CS	Nenapínajte rameno.	Nebezpečí zranění z důvodu vystřelujícího teleskopu!
DA	Sæt ikke løftearmen i spænd.	Risiko for at komme til skade ved opsvingning af løftestang!
DE	Hebel nicht spannen.	Verletzungsgefahr durch hochspringenden Hebel!
EL	Μην κλείνετε το μπράτσο!	Κίνδυνος τραυματισμού από τη συναρμολόγηση μοχλού με ελατήριο.
EN	Do not close the lever arm!	Risk of injury by spring-loaded lever assembly!
ES	No empulgar el brazo.	Peligro de lesión por elevación de la palanca.
ET	Ära suru hooba alla!	Ettevaatust – vinnastatud hoob liigub ülesse.
FI	Älä sulje vartta.	Loukkaantumisvaara – varsi voi ponnahtaa ylös!
FR	Ne pas armer le bras.	Risque de blessure par la remontée rapide des bras !
HR	Polugu ne povlačiti prema dolje.	Opasnost od ozljeda uslijed teleskopske poluge koja iskače !
HU	A kart nem szabad megfeszíteni.	Sérülésveszély a felugró emelőkar által!
IT	Non tendere la leva verso il basso.	Rischio di ferimento in caso di scatto della leva verso l'alto!
HE	עזרה תא רוגסל יא!	זרוע ההרמה עלולה לקפול כלפי מעלה ולגרור לפציעה.
JA	アームを押し下げないでください。	アームが跳ね上がって重傷を負う可能性があります。
LT	Nenuleiskite svertą!	Traumos rizika montuojant mechanizmo svertą!
LV	Nelietojiet piestiprinātu sviru!	Iespējams gūt traumas ar atsperoto atbalsta sviru!
NL	Arm niet onder spanning zetten.	Risico tot kwetsuren door omhoogverende hefboom!
NO	Ikke spenn løftearmen!	Fare for skade ! Kraftig fjærpakke!
PL	Nie opuszczać podnośnika.	Niebezpieczeństwo zranienia przez gwałtownie unoszący się podnośnik!
PT	Não tensionar a alavanca.	Perigo de ferimento, devido ao brusco salto da alavanca
RO	Nu trageți de pârghie!	Pericol de rănire prin pârghia aflată sub tensiunea produsă de arcuri!
RU	Не опускайте рычаг.	Существует опасность получения травмы при выскакивании рычага!
SK	Rameno nenapínajte.	Nebezpečnostv poranenia vyskočením ramena!
SL	Ne zapirajte ročice !	Nevarnost poškodbe pri montaži dviznega vzvoda.
SR	Ne natezati polugu.	Opasnost od povreda zbog teleskopske poluge koja iskače !
SV	Stäng inte lyftarmen!	Skaderisk vid obelastad lyftarm!
TR	Kolu germeyin.	Kolun yukarı fırlaması durumunda yaralanma tehlikesi!
UK	Не опускайте ричаг до низу.	Загроза травмування з причини різкого піднімання важеля!
ZH	请勿夹紧伸缩臂。	伸缩臂上弹会伤人!